

The Effect of Organizational Citizenship Behaviors on Nurses Performance through Nurse's Work Satisfaction in Hospital in Kediri, East Java, Indonesia

Sasi Utami, Anwar Sanusi, Harianto Respati

University of Merdeka Malang, Indonesia

ABSTRACT

This study aims to analyze the influence Organizational Citizenship Behavior on job satisfaction, analyzing the influence Organizational Citizenship Behavior on the performance of nurses, analyze the effect of job satisfaction on the performance of nurses and analyze the effect Organizational Citizenship Behavior on the performance of nurses through job satisfaction of hospital nurses in East Java. The sample in this study were 188 nurses, the sampling technique used proportional random sampling. The analysis technique uses structural equation modeling (SEM) analysis. The analysis results show that Organizational Citizenship Behavior affects job satisfaction. Organizational Citizenship Behavior affects the performance of nurses. Job satisfaction affects the performance of nurses. Organizational Citizenship Behavior affects nurse performance through job satisfaction.

Keywords: Organizational Citizenship Behavior, Job Satisfaction, Nurse Performance.

1. INTRODUCTION

Health services have been provided completely to patients and the general public, nurses have a strategic role in the hospital. A person's performance is important and needs to be measured using clear criteria in carrying out the tasks assigned to him, measurable and clear criteria are used as a reference for measuring a person's ability to carry out tasks. According to Dessler (2016) [1] individual performance is the real achievement of an individual compared to the achievement expected by that individual. Individual performance serves to provide important information to organizations to improve policies, make decisions, and provide feedback to individuals. Individual performance is important to know by management because it will have an impact on organizational performance. Individual performance is a function of one's self-drive and both physical and non-physical abilities in carrying out tasks (Gibson, 2012) [2], and identified through indicators, quality, quantity, effectiveness, timeliness, and independence (Robbins, 2006) [3]. Physical variables that affect individual performance are demographics, while non-physical variables are related, with attitudes shown in the form of behavior such as: job satisfaction and organizational citizenship behavior. Nurse performance is the recording of various work results achieved by nurses or a team of nurses in a hospital in accordance with their respective rights and responsibilities, in accordance with applicable laws and not violating moral and ethical provisions.

Nurse performance is influenced by job satisfaction, according to Musriha (2013) [4]; Farooqui (2014) [5], job satisfaction will increase if a person carries out a job in accordance with the wishes and expectations, conversely, if the desired job does not match expectations, job satisfaction decreases. Shmailan (2016) [6] the results of the study stated that karyawan work as if not only to meet material needs such as decent income, promising careers, but more diverse such as the fulfillment of esteem needs and dignity, satisfaction in carrying out tasks and the desire to continue to excel. According to Luthans (2011) emotional attitude that is fun and loves work is referred to as job satisfaction [7]. Robbins (2016) notes that job satisfaction is an attitude towards one's job as the difference between the amount of income received by an employee and the amount of reward that should be received [8]. Robbins (1996) argues that dissatisfaction at work will reduce performance, such as a workload that is too heavy, a job that is less challenging, a boring job is thought to reduce morale and have an impact on employee performance [9]. The results of the research conducted Platis, that there is a correlation between the performance and job satisfaction of nurses. This work correlation is measured by the nurse performance parameters quantitatively or qualitatively. Quantitative parameters are measured from the target, and qualitative parameters are measured from personality, job satisfaction. One of the indicators of job satisfaction is the personality shown in the nurse's attitude towards work and kJob satisfaction is considered as one of the key factors in shaping employee performance (Platis et al, 2015) [10]. Shahab & Nisa, (2014) stated in his research that job satisfaction has a real and reliable effect on nurse performance [11]. Kaiman (2013) states in the study that job satisfaction has no significant effect on employee work results on the basis of this opinion, it is necessary to re-examine job satisfaction [12].

Nurse performance is influenced by Organizational Citizenship Behavior (OCB), as stated by Luthans (2008). that individual performance, group performance, and organizational performance positively related to OCB [13]. OCB is a Behavior becomes individual choice and inspiration, has nothing to do with the organization's official reward system, but overall it can increase organizational effectiveness (Organ, 1977) [14]. According to Organs (1998) OCB can be measured through several indicators, including Altruism, Conscientiousness, Sportmanship, Courtesy, Civic Virtue, OCB has an important role in the organization [15]. Research conducted by Dinka (2018), only three dimensions of OCB are used, namely Altruism, conscientiousness and civic virtue, the results of the study state that there is a positive, strong and significant relationship between employee performance and altruism, while conscientiousness shows a positive, significant and weak relationship. , civic virtue shows no relationship with employee performance[16]. OCB has positive attitudes and behaviors, which are necessary to maintain the organization. The results of research (Eyupoglu, 2016) on OCB Academic Staff in North Cyprus stated that there are several dimensions of OCB that do not support employee performance [17]. Akira & Jatmika (2015) stated that OCB behavior tends to be low, due to the high workload and limited number of nurses, conditions like this will cause the performance of nurses to be low as a result of patient and patient's family dissatisfaction with services [18]. Lestari (2018) states that organizational success depends on employee performance and variables that affect employee performance, one of which is OCB [19]. Job satisfaction is influenced by OCB, (Eyupoglu, 2016) the results of his research state that the overall dimensions of OCB have an effect on job satisfaction [17]. (Chaerani et al, 2018) the results of the study state that OCB has a positive and significant relationship with job satisfaction except that sportmanship does not have a significant effect on job satisfaction [20].

The phenomenon that occurs is that patients often complain that nurses are not friendly when serving patients, are less responsive to patient complaints, waiting for long queues, nurses often talk with colleagues who have nothing to do with work. Research conducted by Khan (2007) states that 90% of patients feel uncomfortable communicating with nurses, and 84% of these have the experience of nurses not paying attention to patient needs, especially at night [21]. The mentoring behavior by nurses shows a significant relationship with patient satisfaction, but there are still 15.2% who state that the mentoring behavior by nurses does not satisfy the patient, (Gunarsa, 2012) [22]. Employee group most in the hospital are nurses (Kemenkes RI: No.340 / MENKES / PER / III / 2010). The task of nurses is so heavy that it certainly requires professionalism to achieve high performance. Performance can be maintained if there is encouragement or motivation, developing abilities, increasing job satisfaction, achieving personal potential that is beneficial to individuals and organizations (Bintoro & Daryanto, 2017) [23]. Organization needs to involve the role of employee performance, OCB and job satisfaction in nature order to achieve that goal. Hospitals in the future are required to provide better services in all sectors that are needed by patients, so that patients who are currently and after treatment are satisfied. Patient satisfaction is a form of expression because they feel relieved, comfortable, friendly, fast and attentive to nurses who have a good performance in the hospital.

This study aims to analyze the influence Organizational Citizenship Behavior on job satisfaction, analyzing the influence Organizational Citizenship Behavior on the performance of nurses, analyze the effect of job satisfaction on the performance of nurses and analyze the effect Organizational Citizenship Behavior on the performance of nurses through job satisfaction of hospital nurses in East Java.

2. LITERATURE REVIEW

2.1. Performance

The definition of performance according to Gibson (2012) is the result of work that is associated with organizational desires, such as quality, efficiency and other work effectiveness criteria [2]. Ghiselli & Brown (1955) provide an understanding of performance is the level of individual success in carrying out their obligations and being responsible, besides performance is determined by past work experience, age and gender [24]. McClay & Cadeck (1994), providing an understanding of performance is behavior or action in accordance with organizational goals, this assessment specification represents an assessment decision made by experts [25]. Byars & Rue (2000) defines performance as the acquisition of the relationship between effort, ability, and role perception [26]. The definition of effort is the result of motivation, which means the amount of energy, both physical and mental, of a person is used to carry out a task. Abilities are personal conditions used in carrying out a job. Role perception means the direction that an employee believes to channel all his abilities in doing his job well. Performance is work that is related to organizational goals, such as quality, efficiency and other work effectiveness (Gibson, 2012) [2]. (Wexley & Yukl, 1984) argue that performance can be defined as the behavior shown by a person in carrying out tasks, outcomes and assessments including effort, loyalty, potential, leadership and work morale [27].

2.2. Nurse Performance

Nurse performance is the achievement of the work of nurses and a team of nurses in an organization in accordance with their duties and responsibilities, formal, does not violate the law in accordance with morals and ethics (Nawawi, 2013) [28]. Nurse performance can be seen through the assessment process using assessment instruments. Performance is a mixture of knowledge and abilities possessed by nurses, obtained through formal nursing education and applied in providing services to patients

according to their duties, functions and competencies (Ali, 2008)[29]. Sulistyowati (2012) argues that competent nurses are nurses who have performance in accordance with standards of nursing practice, vision and mission of the hospital, nurses who have these competencies are expected to have an impact on hospital performance [30]. Potter et al (2017), stated that nurse performance is a competency possessed by nurses related to job descriptions in the standard process of nursing care of a nurse [31].

2.3. Job satisfaction

Job satisfaction is the employee's perception of how well the work results provide things that are considered important. There are three things related to job satisfaction. First, job satisfaction is an emotional response to work situations, it can be seen and predicted. Both job satisfaction shows how well the results achieved can meet or exceed expectations. For example, if an employee feels that he has worked harder than others, but receives less appreciation from the other person, then the employee is dissatisfied. Likewise, if employees feel that they are treated well and are rewarded appropriately, they are satisfied. Third, job satisfaction reflects attitudes related to work (Luthans, 2011) [7].

Job satisfaction creates a positive situation in the work environment because it has an important meaning for the organization. The influence factor of job satisfaction will be known by looking at things that can encourage job satisfaction. According to Bintoro & Daryanto (2017) the driving factors for job satisfaction are psychological, social, physical, and financial factors [23]. Factors related to employee psychology are psychological factors, such as interests, work comfort, the job itself, talents and skills. Social factors, which relate to fellow employees, superiors and employees of different types of work. Physical factors, are factors that are closely related to physical conditions, physical work environment, physical environment including the type of work, setting work time and rest time, room temperature, lighting, ventilation, employee health condition, age. Financial factors, related to employee welfare guarantees which include the payroll system and the amount of salary, social security, benefits, facilities provided, promotions.

2.4. Organizational Citizenship Behavior (OCB)

Every employee in carrying out their duties is in accordance with the job description or standard operating procedures, but it is even better if the employee can work more than the SOP or not just a job responsibility. Employees with high levels of OCB are able to provide an overview of personal relationships in the work done by others, such as training new people, caring for organizational property, and having the hope of remaining in the organization (Organ et al., 2006) [32]. Organ (1998) provides a definition of "Organizational Citizenship Behavior: individual behavior that is discretionary, not directly or explicitly recognized by the formal reward system, and in aggregate promotes the efficient and effective functioning of the organization (individual behavior that is freely explicit or indirectly recognized by the formal system, and as a whole functions effectively and efficiently in an organization) [15]. Luthans (2011) added that voluntary behavior that is done to help the work of a boss or coworker can increase organizational effectiveness, through direct or indirect social influence based on increasing interpersonal relationships [7]. Citizenship behavior is not explained in formal employment, nor is it rewarded. Brief (1986) supports Organs research related to the importance of effectiveness for this behavior which is called OCB behavior. Furthermore, Organ (1998) states that the overall or aggregate function refers to all people in a team, department, or organization [15]. If there is only one person, then OCB has no real influence on an organization, if in an organization as a whole, members have good OCB behavior, it will have a real impact on the organization.

2.5. Hypothesis

The research hypothesis is as follows:

- 1) There is an influence of Organizational Citizenship Behavior on the job satisfaction of nurses in hospitals in East Java.
- 2) There is an influence of Organizational Citizenship Behavior on the performance of nurses at hospitals in East Java.
- 3) There is an effect of job satisfaction on the performance of nurses at hospitals in East Java.
- 4) There is an influence of Organizational Citizenship Behavior on the performance of nurses through job satisfaction at hospitals in East Java.

3. RESEARCH METHODS

3.1. Population and Research Sample

The study population was nurses who worked in class B public hospitals in the City and District of Kediri. The number of nurses was 911 nurses spread in the general hospital, Pare Regional Hospital, Gambiran II Hospital, Baptis Hospital and Bhayangkara Hospital. The sample in this study were nurses who worked in class B hospitals in the city and district of Kediri. The sampling technique was proportional random sampling. Respondents of this study were male and female nurses who have worked at the hospital for at least 1 year. The number of samples taken using the Slovin formula, in order to obtain a total sample of 188 nurses.

3.2. Operational Definition of Variables

a. Organizational Citizenship Behavior (X1)

Organizational Citizenship Behavior is a nurse's contribution that exceeds the demands of a role in the workplace and can be measured through indicators: Altruism or helpful attitudes, Conscientiousness or obedience to regulations, Civic Virtue or involvement in organizational functions, Sportmanship or sportsmanship and Courtesy or good behavior and polite.

b. Job Satisfaction (Y1)

Job satisfaction is the result of nurses' perceptions of how well the nurse's job provides results, which are considered important, measured through indicators: the job itself, promotion, supervision, co-workers and working conditions.

c. Employee Performance (Y2)

Employee performance is the work achieved by a nurse for the work that is their responsibility in order to achieve organizational goals. Indicators for measuring employee performance are: quality, quantity, timeliness, effectiveness, and independence.

3.3. Data Analysis Technique

The data analysis technique used in this research is descriptive analysis and analysis of Structural Equation Modeling (SEM). SEM is an analytical model that is used as a tool in this study. Based on the explanation in the previous chapter, the pattern of relationship between the variables to be studied is a causal relationship of one or more exogenous variables to one or more endogenous variables. Structural Equation Modeling (SEM) is a statistical technique that tests a series of relatively complex relationships simultaneously. SEM processing uses AMOS 18. The relationship can be built between one or several dependent variables with one or several independent variables and can be in the form of factors or constructs, which are built from several indicator variables. These variables can be in the form of a single variable that is observed or measured directly (Ferdinand, 2002) [33].

4. RESEARCH RESULTS AND DISCUSSION

4.1. Research result

Respondent Identity

Based on tabulation of the results of the respondent's questionnaire, the characteristics of the respondents were as follows:

**Table 1
Respondent Characteristics Data**

No.	Information	Frequency	Percentage
Gender			
1	Male	35	18.6
2	Women	153	81.4
	amount	188	100.0
Age			
1	18-25 years	77	41.0
2	26 - 36 years	78	41.5
3	> 36 years	33	17.5
	amount	188	100.0
Level of education			
1	Undergraduate Degree (S1)	159	84.6
2	Diploma	29	15.4
	amount	188	100.0
Marital status			
1	Married	98	52.1
2	Single	90	47.9
	amount	188	100.0
Years of service			
1	15 years	105	55.9
2	6 - 10 years	57	30.3
3	> 11 years	26	13.8
	amount	188	100.0

Source: Processed data.

Results of Structural Equation Modeling Analysis

The results of the Structural Equation Modeling Analysis for Organizational Citizenship Behavior (OCB) variables, job satisfaction, and nurse performance are described below:

a. Evaluation of Data Normality

Based on the results of the analysis of the Amos program, it shows that the multivariate value of 1.42 is between the critical ratio value of Skewnes and the kurtosis (-2.58 and 2.58.).

b. Outlier Detection Results

The lowest mahalanobis distance value was 14.89 and the highest was 93.08. The comparison of the highest and lowest numbers shows that there is no mahalanobis d-squared value that exceeds the calculated Chi Square number (118,599), thus the observation data does not have any outliers.

c. Multicollinearity Test Results

Multicollinearity evaluation is to determine the presence of two or more exogenous variables that have a very strong relationship or have high similarities. The results show that the correlation value among the research indicators does not exceed 0.5. This shows that there is multicollinearity.

d. Structural Equation Model Test Results

Assumption test results Structural Equation Modeling (SEM) proves that normally distributed data does not have multicollinearity problems, and outliers, observational data have met the requirements to be tested using a model structure, assisted by the AMOS (Analysis Moment of Structure) program. The results of the structural model test can be seen in the following figure.

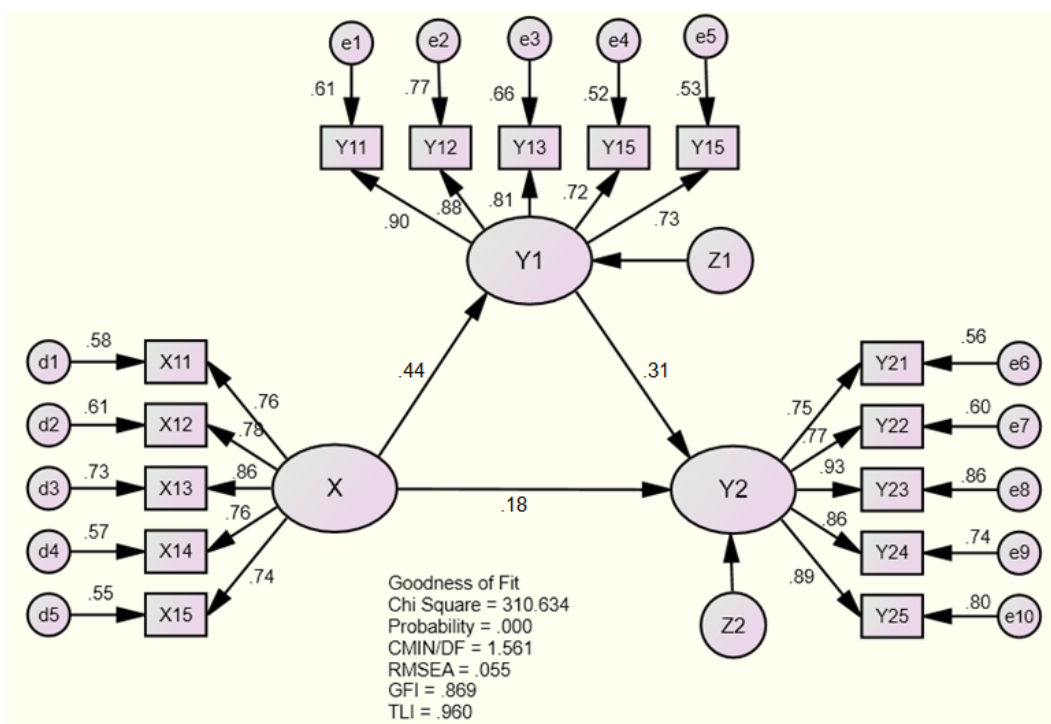

Picture 1
SEM Test Results (on model suitability analysis)
 Source: Data processed.

Analysis of the suitability of the model (Fit model), after evaluating the assumptions Structural Equation Modeling (SEM), then evaluate the suitability of the model using various criteria from Goodness-of-fit. The criteria for acceptance of a structural model is done by comparing the size of the suggested cut-of value. The goodness-of-fit index value was compared with the cut-of value (Hair, 2009) [34]. The comparison results of the SEM Goodness-of-fit index value and the cut-of value are as in Table 2 below.

Table 2
Comparison of Results, Cut Offs and Model Evaluation

Goodness-of-fit Index	Result	Cut-off Value	Model Evaluation
Chi-Square	310,634	232,911	Marginal
Probability	0.000	.> 0.05	Marginal
RMSEA	0.055	<0.08	Good
GFI	0.869	> 0.09	Good
CMIN / DF	1,561	<2	Good
TLI	0.960	> 0.95	Good

Source: Processed data.

Based on Table 2 shows the results of the structural model testing. The evaluation results show that the absolute criterion size is the value of Chi square = 310.634 > 232.911, marginal evaluation with a significant level of 0.000 < 0.05, marginal evaluation, the Chi square value should be smaller than the cut-off value and the probability is greater than the cut-off value, meaning that it is not as recommended, but other eligibility values are in accordance with the size of the incremental criteria such as RMSEA, GFI, and CMIN / DF, TLI has met the recommended cut-off value, there are only two, namely probability and Chi square, the calculated value is marginal, thus The structural equation model built is acceptable, then the analysis of the influence between research variables can be used and proves the research hypothesis.

1) Hypothesis Test

Four hypotheses are proposed to be tested, the four hypotheses are explained as follows:

Table 3 Hypothesis test

No.	Exogenous Variables	Intervening Variables	Endogenous Variables	Direct Effect	P value	Indirect Effect	Total Effect	Result
1	Organizational Citizenship Behavior (X1)	Job Satisfaction (Y1)	-	0.44	0.000	-	-	Accepted
2	Organizational Citizenship Behavior (X1)	-	Nurse Performance (Y2)	0.18	0.047	-	-	Accepted
3	-	Job satisfaction	Nurse Performance (Y2)	0.31	0.007	-	-	Accepted
4	Organizational Citizenship Behavior (X1)	Job Satisfaction (Y1)	Nurse Performance (Y2)	0.18	-	0.14	0.32	Accepted

Source: Processed data.

Table 3. Through Path Analysis, explaining the first, the standard coefficient of direct influence between OCB variables, on nurse performance is 0.44, meaning that there is a significant positive effect of OCB variables on nurse performance. The standard coefficient of indirect influence between OCB variables, transformational leadership on nurse performance, through Path analysis is 0.14. This means that there is a positive and significant influence between OCB variables on nurse performance. The positive effect is significant between job satisfaction variables on nurse performance with a standard coefficient of 0.31. Job satisfaction is a mediating variable partially which mediates the relationship between the OCB variable and the nurse's performance. The nature of this mediation depends on the comparison of the indirect effect on the total effect which is called the variance account for (VAF) value. Hair (2014) states VAF is in the range of 20% to 80%. The total effect between the OCB variable on the nurse's performance is 0.32. There is a positive and significant influence between the OCB variable on nurse performance, meaning that the standard coefficient value of the total effect of the OCB variable on nurse performance is greater than the direct effect of the three variables on nurse performance. Job satisfaction is proven to mediate OCB, towards nurse performance, hypothesis four is proven. There is a positive and significant influence between the OCB variable on nurse performance, meaning that the standard coefficient value of the total effect of the OCB variable on nurse performance is greater than the direct effect of the three variables on nurse performance. Job satisfaction is proven to mediate OCB, towards nurse performance, hypothesis four is proven. There is a positive and significant influence between the OCB variable on nurse performance, meaning that the standard coefficient value of the total effect of the OCB variable on nurse performance is greater

than the direct effect of the three variables on nurse performance. Job satisfaction is proven to mediate OCB, towards nurse performance, hypothesis four is proven.

4.2. Discussion of Research Results

1) The Effect of Organizational Citizenship Behavior on Job Satisfaction

The results of the study in Table 20 show that OCB has a significant positive effect on job satisfaction, the better OCB behavior will have an impact on increasing job satisfaction. Professional nurses are nurses who carry out their duties and outside of their main duties such as helping sincerely colleagues in a team to heal patients, nurses are satisfied if they can carry out their duties according to their profession, besides that nurses are also involved in the organization, from the results of research by female nurses more than male nurses. The nurse is the person closest to the patient and the patient's family, female nurses are more flexible in communicating with patients, with the age of nurses who are still productive, and experienced, the patient will be more free to complain about the illness suffered to the nurse. Nurses can convey patient complaints to hospital management, so it is very beneficial if nurses are involved and married nurses are certainly more responsible for their involvement so that they can reduce the patient's pain burden and the patient can recover quickly. The duties of nurses are based on standard operating procedures and are carried out as a team work, colleagues in the team will feel happy if no one is late, tolerance at work is also needed, which is no less important, nurses and colleagues create a pleasant working atmosphere, in conditions like this the nurses get satisfaction at work, nurses who feel satisfied will work better and are loyal to the hospital. This research is consistent with research conducted, Eyupoglu (2016) [17], Lestari (2018) [19]. Chaerani (2018) in his research states that simultaneously OCB has an effect on job satisfaction [20], however partially there are two unsupportive OCB variables, namely sportmanship and courtesy on job satisfaction.

2) The Effect of Organizational Citizenship Behavior on Nurse Performance

Organizational Citizenship Behavior (OCB) has a significant positive effect on nurse performance, which means that the size of OCB has an impact on nurse performance. The voluntary behavior shown by nurses towards colleagues, so that colleagues are motivated to immediately complete the tasks that are their responsibility, the productivity of these colleagues can increase. Helpful behavior, for nurses who are already senior, will help spread a good example for new nurses, and spread throughout the work unit. As a tangible form of OCB behavior, nurses coming before the work schedule starts will help colleagues whose workload exceeds capacity, this behavior can increase morale and closeness and feelings of belonging among group members so that it can improve performance, nurses obey the rules, especially nurses who are married, are involved in activities and are accountable for their involvement and maintain the good name of the organization, nurses help leaders provide valuable suggestions and feedback for nurses and can increase the effectiveness of the work unit. Nurses who are polite and avoid conflict, tolerate colleagues. as well as creating a pleasant working atmosphere will help leaders avoid a management crisis. The results of this study are supported by Lestari (2018), which states that OCB has a significant effect on employee performance [19]. This research is not in line with the results of the study (Eyupoglu, 2016) which states that simultaneously OCB affects employee performance, however partially there are several dimensions of OCB that do not support employee performance [17]. Akira & Jatmika (2015) state that OCB behavior tends to be low, because of the high workload and limited number of nurses, conditions like this will cause the performance of nurses to be low as a result of patient and patient's family dissatisfaction with services [18]. Based on the description above, it can be explained that there are several things that must be explained related to OCB in a hospital institution, namely nurses should tolerate, maintain working relationships and try not to create or exaggerate problems with other nurses so as to create a good and conducive work environment. . This needs to be done so that nurses have high enthusiasm to carry out their duties and improve their performance. states that OCB behavior tends to be low, due to the high workload and limited number of nurses, this condition will cause the performance of nurses to be low as a result of patient and patient's family dissatisfaction with services [18]. Based on the description above, it can be explained that there are several things that must be explained related to OCB in a hospital institution, namely nurses should tolerate, maintain working relationships and try not to create or exaggerate problems with other nurses so as to create a good and conducive work environment. . This needs to be done so that nurses have high enthusiasm to carry out their duties and improve their performance. states that OCB behavior tends to be low, due to the high workload and limited number of nurses, this condition will cause the performance of nurses to be low as a result of patient and patient's family dissatisfaction with services [18]. Based on the description above, it can be explained that there are several things that must be explained related to OCB in a hospital institution, namely nurses should tolerate, maintain working relationships and try not to create or exaggerate problems with other nurses so as to create a good and conducive work environment. . This needs to be done so that nurses have high enthusiasm to carry out their duties and improve their performance. Such conditions will cause the performance of nurses to be low as a result of the patient's and the patient's family's dissatisfaction with services [18]. Based on the description above, it can be explained that there are several things that must be explained related to OCB in a hospital institution, namely nurses should tolerate, maintain working relationships and try not to create or exaggerate problems with other nurses so as to create a good and conducive work environment. This needs to be done so that nurses have high enthusiasm to carry out their duties and improve their performance. Such conditions will cause the

performance of nurses to be low as a result of the patient's and patient's family's dissatisfaction with services [18]. Based on the description above, it can be explained that there are several things that must be explained related to OCB in a hospital institution, namely nurses should tolerate, maintain working relationships and try not to create or exaggerate problems with other nurses so as to create a good and conducive work environment. . This needs to be done so that nurses have high enthusiasm to carry out their duties and improve their performance. It can be explained that there are several things that must be explained related to OCB in a hospital institution, namely nurses should tolerate, maintain working relationships and try not to create or exaggerate problems with other nurses so as to create a good and conducive work environment. This needs to be done so that nurses have high enthusiasm to carry out their duties and improve their performance. It can be explained that there are several things that must be explained related to OCB in a hospital institution, namely nurses should tolerate, maintain working relationships and try not to create or exaggerate problems with other nurses so as to create a good and conducive work environment. This needs to be done so that nurses have high enthusiasm to carry out their duties and improve their performance.

3) Effect of Job Satisfaction on Nurse Performance

Job satisfaction has a significant effect on the performance of nurses, this shows that any increase in job satisfaction will increase performance. Nurses who are satisfied with their work are motivated to increase their performance beyond organizational expectations. Job satisfaction is a collection of pleasant and unpleasant feelings about work. Age, years of service, education level, gender have an effect on job satisfaction. The older the age, the higher the level of understanding of the job, the longer the work period the more experienced and skilled, the higher the education, the more extensive the knowledge, the more involved in the organization, the more flexible female nurses and higher levels of satisfaction. Types of job satisfaction include the job itself, related to the competence of nurses so that they can take action to deal with patients including checking blood pressure, body temperature, communication with patients so that the results obtained can be used for feedback, so that nurses provide thorough nursing care, precisely according to what the patient needs. Good relationships with coworkers and work teams will support in completing tasks such as reviewing the nursing history of all transfer patients, which is no less interesting to increase job satisfaction is the existence of a development program based on work performance, good supervision of its members, as well as the existence of facilities that support work, the existence of medical equipment that can be used to collect patient data using appropriate and good methods, so that the nurse works happily there is no anxiety in her. Research that supports Platis (2015) [10], Shmailan (2016) [6], Ritonga (2018) [36], which does not support this study Kaiman (2013) [12], Shahab & Nisa (2014) [11].

4) Pengaruh Organizational Citizenship Behavior terhadap Kinerja Perawat melalui Kepuasan kerja

Job satisfaction mediates the effect of OCB on nurse performance, if OCB increases, nurses feel satisfied at work, this has an impact on increasing nurse performance. This research is supported by Lestari (2018) which states that OCB behavior will improve employee performance [19]. Characteristics of nurses such as gender, increasing age, marital status affect the performance of nurses, education level affects work performance, such as sincere behavior by male nurses is more valued than women, OCB behavior with a satisfied attitude as a mediation towards work, program development or promotion, colleagues who help each other, a clean and comfortable work environment will further improve performance beyond organizational expectations.

5. CONCLUSIONS AND SUGGESTIONS

5.1. Conclusion

Based on the results of research and discussion of research results, several conclusions can be obtained as follows:

1. The results showed that the higher the Organizational Citizenship Behavior, the higher the job satisfaction of the nurses. The high job satisfaction of nurses is manifested in the form of work in accordance with their competence. Nurses who have high education, productive age, long service life and are married, job satisfaction will be better able to carry out their duties especially driven by the involvement of nurses in the organization. a trusted leader, sustainable commitment will further increase job satisfaction if promotion is done fairly, supportive colleagues, supervision who understands the needs of members and a good environment to work. Hospitals need to pay attention to nurses' OCB behavior, so that they can carry out a better job.
2. The results showed that the higher the Organizational Citizenship Behavior, the higher the nurse's performance. Good performance is manifested in the form of timely nursing care, such as giving medication to patients, diagnosing, providing training opportunities for nurses. Hospitals need to pay attention to and maintain Organizational Citizenship Behavior (OCB), with sincere behavior without additional compensation and the involvement of nurses in the hospital will have an impact on high performance and bring the hospital's good name.
3. Job satisfaction has a significant positive effect on nurse performance. The more appropriate the work done by nurses with a background that is owned, the higher the job satisfaction is, consequently the higher the nurse's performance. Job satisfaction is obtained because nurses have the ability and competence to carry out nursing care. Therefore, the hospital needs to increase the job satisfaction of nurses so that performance can better exceed the expectations of the hospital.

4. Job satisfaction has an important role in mediating Organizational Citizenship Behavior on nurse performance. The mediating role of job satisfaction is manifested in the form of maintaining and enhancing the role of OCB by assigning tasks according to the goals and expectations of nurses so that it can improve nurse performance more than the expectations of the hospital, ultimately having an impact on success and bringing the hospital's good name.

5.2. Suggestions

1. For hospital management
 - a. The results of this study are expected that hospital management maintains the performance of nurses in relation to timeliness in carrying out nursing care tasks for patients, besides that company management strives to care about patient needs, continues to make nursing plans for each patient, collects patient health status data systematically, this is to facilitate searching and health records of a patient, as well as reviewing and revising nursing actions based on patient responses.
 - b. The results of job satisfaction research, management should still maintain satisfaction at the job itself, besides that management should increase the job satisfaction of nurses through, supervision is willing to appreciate the results of the work of nurses, in the field of promotion on promotion policies should be done fairly, it is suggested that there is team cohesiveness in carrying out tasks, and need to pay attention to adequate nurse work space.
 - c. The results of research related to the OCB behavior of nurses should be maintained to be accountable for the involvement of nurses in the hospital, besides that management should pay attention to matters related to OCB behavior, such as the presence of fellow nurses who help other nurses who are unable to attend and maintain good relationships with coworkers, involvement of nurses in the hospital, increasing compliance with hospital regulations.
2. The researcher continued, in order to get maximum results, researchers could develop this research by adding variables, different locations, or different research objects.

REFERENCES

1. Dessler, Gary. 2016. *Human Resource Management*. London: Pearson Education
2. Gibson, J. L., Ivancevich, J. M., Donnelly, J. H. 2012. *Organizations: Behavior, Structure, Processes*. New York: McGraw Hill.
3. Robbins, Stephen P. 2006. *Perilaku Organisasi. Edisi kesepuluh*. Jakarta: PT Indeks Kelompok Gramedia.
4. Musriha, M. 2013. The Impact of Individual Characteristics and Organization Culture on Performance and Career Development of Employees Case studies Five Star Hotel in Surabaya Indonesia. *Journal of Business and Management*. ISSN: 2319-7668. Vol. 14(3): 21–27.
5. Farooqui, Safia, & Nagendra, Asha. 2014. The Impact of person Organization Fit on Job Satisfaction and Performance of the Employees. *Procedia Economics and Finance*. Vol. 11:122-129
6. Shmailan, A. S. Bin. 2016. The Relationship Between Job Satisfaction, Job Performance And Employee Engagement: An Explorative Study. *Issues in Business Management and Economics*. ISSN 2350-157X. Vol. 4(1): 1–8.
7. Luthans, F. 2011. *Organizational Behavior: an Evidence-Based Approach*. New York: The McGraw-Hill.
8. Robbins, S. P., & Judge, T. A. 2016. *Essentials of Organizational Behavior*. England: Pearson. Steers, R.M. & Porter, L.W. (Eds.) 1983. *Motivation and work behavior*. New York: McGrawHill.
9. Robbins, Stephen P. 1996. *Perilaku Organisasi, Konsep, Kontroversi dan Aplikasi*. Alih Bahasa: Hadyana Pujaatmaka. Edisi Keenam. Penerbit PT.Bhuana Ilmu Populer, Jakarta, hlm 181-182.
10. Platis, C., Reklitis, P., & Zimeras, S. 2015. Relation between job satisfaction and job performance in healthcare services. *Procedia Social and Behavioral Sciences*. 175: 480-487.
11. Shahab, M. A., & Nisa, I. 2014. The Influence of Leadership and Work Attitudes toward Job Satisfaction and Performance of Employee. *International Journal of Managerial Studies and Research*. ISSN 2349-0330. Vol. 2(5): 69–77.
12. Kaiman, H. 2013. Leadership Behavior and Commitment. The Effect to Employee Job Satisfaction and Employee Performance on Department of Population and Civil Registration Jakarta, Indonesia. *International Journal of Business and Management Invention*. ISSN: 2319-8028. Vol. 2(9): 57–62.
13. Luthans, F., Norman, S. M. 2008. The Mediating Role of Psychological Capital in the Supportive Organizational Climate-Employee Performance Relationship. *Journal of Organizational Behavior*. No. 29: 219-238.
14. Organ, D. W. 1977. A Reappraisal and Reinterpretation of the Satisfaction-Causes-Performance Hypothesis. *Academy of Management*. Vol. 2: 46-53.
15. Organ, D. W. 1998. *Organizational Citizenship Behavior: the Good Soldier Syndrome*. Lexington MA: Lexington Books.
16. Dinka, Desta D., 2018. Organizational Citizenship Behaviour and Employees' Performance Assessment: The Case of Dire Dawa University. *American Journal of Theoretical and Applied Business*. ISSN: 2469-7834. Vol. 4(1): 15-26.
17. Eyupoglu, Serife Z. 2016. The Organizational Citizenship Behaviour of Academic Staff in North Cyprus. *Procedia Economics and Finance*. Vol. 39: 701-704.

18. Akira & Jatmika, D. 2015. Organizational Citizenship Behavior (OCB) pada Perawat di Rumah Sakit Ibu dan Anak "X" di Bandung. *Jurnal PSIBERNETIKA*. Vol. 8(1): 48-61.
19. Lestari, E. R., & Ghaby, Nur K.F. 2018. The Influence of Organizational Cizenship Behavior (OCB) on Employee's Job Satisfaction and Performance. *Jurnal Teknologi dan Manajemen Agroindustri*. ISSN 2252-7877. Vol. 7(2): 116-123.
20. Chaerani, Safira., & Nimran, U. 2018. Pengaruh Organizational Citizenship Behavior (OCB) Terhadap Kepuasan Kerja Karyawan pada PT Bank Negara Indonesia. *Jurnal Administrasi Bisnis*. Vol. 60(2): 134-142
21. Khan, M. H., *et al.* 2007. Patient Satisfaction with Nursing Care. *Rawal Medical Journal*. Vol. 32(1): 27-29.
22. Gunarsa, Yulia Singgih. 2012. *Psikologi Untuk Keluarga*. Jakarta: Penerbit Libri.
23. Bintoro & Daryanto, 2017. *Manajemen Penilaian Kinerja Karyawan*. Yogyakarta: Gava Media
24. Ghiseli, E.E., & Brown, C.W. 1955. *Personnel and Industrial Psychology*. New York: Mc. Graw Hill Book Company Inc.
25. McClay & Cadeck (1994, 25'
26. Byars, L. L. & Rue, L. W. 2000. *Human Resource Management, 6th ed.* Boston: Irwin/McGraw-Hill.
27. Wexley, K. N., & Yukl, G. A. 1984. *Organization Behavior and Personal Psychology*. Illinois: Irwin.
28. Nawawi, I. 2013. *Budaya organisasi kepemimpinan dan Kinerja*. Jakarta: PT. Fajar Iterpratama Mandiri.
29. Ali, Muhammad. 2008. *Psikologi Remaja*. Jakarta: PT BumiAksara.
30. Sulistyowati, D. 2012. Analisis Faktor-Faktor yang Mempengaruhi Pencapaian Target Kinerja Individu Perawat Pelaksana Berdasarkan Indeks Kinerja Individu di Gedung A Rumah Sakit Umum Pusat Nasional. Dr. Cipto Mangunkusumo. *Tesis*. Fakultas Ilmu Keperawatan. Universitas Indonesia.
31. Potter, P. A., *et al.* 2017. *Fundamental of Nursing*. St. Louis: Mosby Elsevier.
32. Organ, D. W., *et al.* 2006 *Organizational Citizenship Behavior. Its Nature, Antecedents, and Consequences*. California: Sage Publications.
33. Ferdinand, Augusty. 2002. *Stuctural Equation Modelling*. Semarang: Undip Press.
34. Hair, J. F., Black, W. C., Babin, B. J., & *et al.* 2009. *Multivariate data analysis, 7th ed.* Upper Saddle River: Prentice Hall.
35. Hair, 2014. *Multivariate Data Analysis, New International Edition.*, New Jersey : Pearson.
36. Ritonga, E. E. 2018. Peran Organizational Citizenship Behavior Sebagai Pemediasi Pengaruh Kepuasan Kerja Terhadap Kinerja Perawat. *Jurnal Ekonomi Islam*. Vol. 14(1): 71-86.